

## Temperature Stabilized Semiconductor Laser Module

### Key Features:

- ◆ Fiber Coupled or Free Space
- ◆ Circularized Laser Beam
- ◆ Constant Optical Power
- ◆ TTL Modulation Option
- ◆ Low Optical Noise
- ◆ ESD Protection
- ◆ Plug & Play

### Applications:

- ◆ Bio Technology
- ◆ Photo Finishing
- ◆ Semiconductor Instrument
- ◆ Medical Instrument
- ◆ Scientific Research



The FreeBeam™852 Laser Module is a highly integrated diode laser module with thermal electrical cooler, laser power control and protection circuits. For free space application, you can choose either collimated circular beam at 2.4mm diameter or collimated elliptical beam at 1.3mmX2.6mm. For fiber coupled out put, you can choose single mode fiber, polarization maintain fiber, 50um, 100um, 200um and 400um core diameter multi mode fiber with FC/PC or SMA connector.

FreeBeam™852 features very low optical noise and up to 100 KHz TTL modulation capability. Laser output power can be remotely controlled with 0 ~ 2.5V DC voltage through electrical cable connected or locally controlled with potential meter mounted on the back panel. The FreeBeam™852 Laser Module comes with two different packages for you to choose from, box style and tube style.

The FreeBeam™852 Laser Module is a Class III b laser product.



## Temperature Stabilized Semiconductor Laser Module

### Specifications:

Wavelength	852±5nm
Output Power( free space)	Max 150mW
Output Power( fiber coupled)	Max 2W
Longitudinal Mode	Multi Mode
Power stability	<2%
Noise(RMS)	<0.2%
Beam pointing stability	<10urad/°C
Polarization	100 : 1
Beam diameter	2.6 X 1.3mm(Elliptical Beam)
Beam diameter	2.4mm(Circularized Beam)
Beam divergence	0.3 X 0.6mrad(Elliptical Beam)
Beam divergence	0.6mrad(Circularized Beam)
Operation Voltage	9V+/- 0.5V DC
Operation Current	TEC Max 2.5 A, LD Max 140mA
Operation Temperature	0°C to 40°C
Warm Up Time	5 minutes
Laser Diode Life Time	10000hrs(MTBF)
Mechanical Size(Box)	100mm(L)X44mm(W)X38.5mm(H)
Mechanical Size(Tube)	φ40mmX116.3mm
9V DC Power Supply Size	110mm(L)X50mm(W)X20mm(H)
RF Input(for tube)	SMA Receptacle
RF Input(for box)	SAMTEC #: MMCX-J-P-X-RA-TH1*
Electrical Interface(for box)	SAMTEC #: EHF-105-01-L-D-RA*
Fiber type	Single mode and Multi mode(50um, 100um, 200um, 400um)
Connector Type	FC/PC or SMA
Warranty	One Year

\*You can find mating connector information at [www.samtec.com](http://www.samtec.com)

### Electrical Pin Assignment:

Number	Function
Pin 1	+9V DC
Pin 2	+9V DC
Pin 3	+9V DC
Pin 4	+9V DC
Pin 5	Power GND
Pin 6	Power GND
Pin 7	Power GND
Pin 8	Power GND
Pin 9	Power Setting
Pin 10	Internal Testing Pin

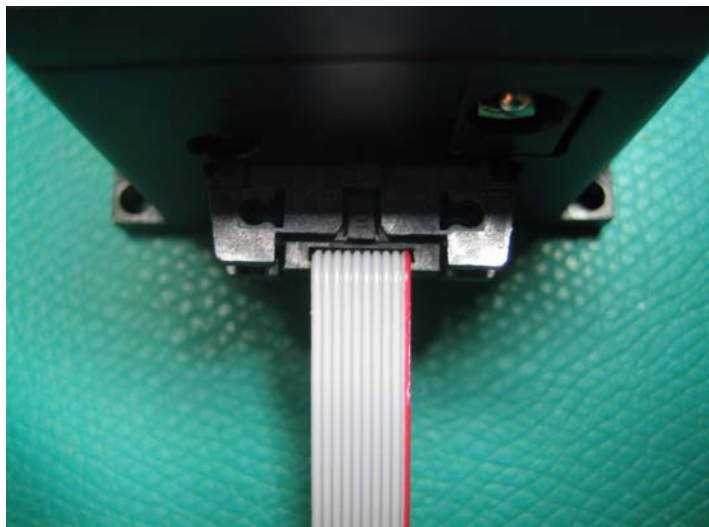

## Temperature Stabilized Semiconductor Laser Module

Pin 10 Pin 1

### Free Space Mechanical Dimension (BOX):

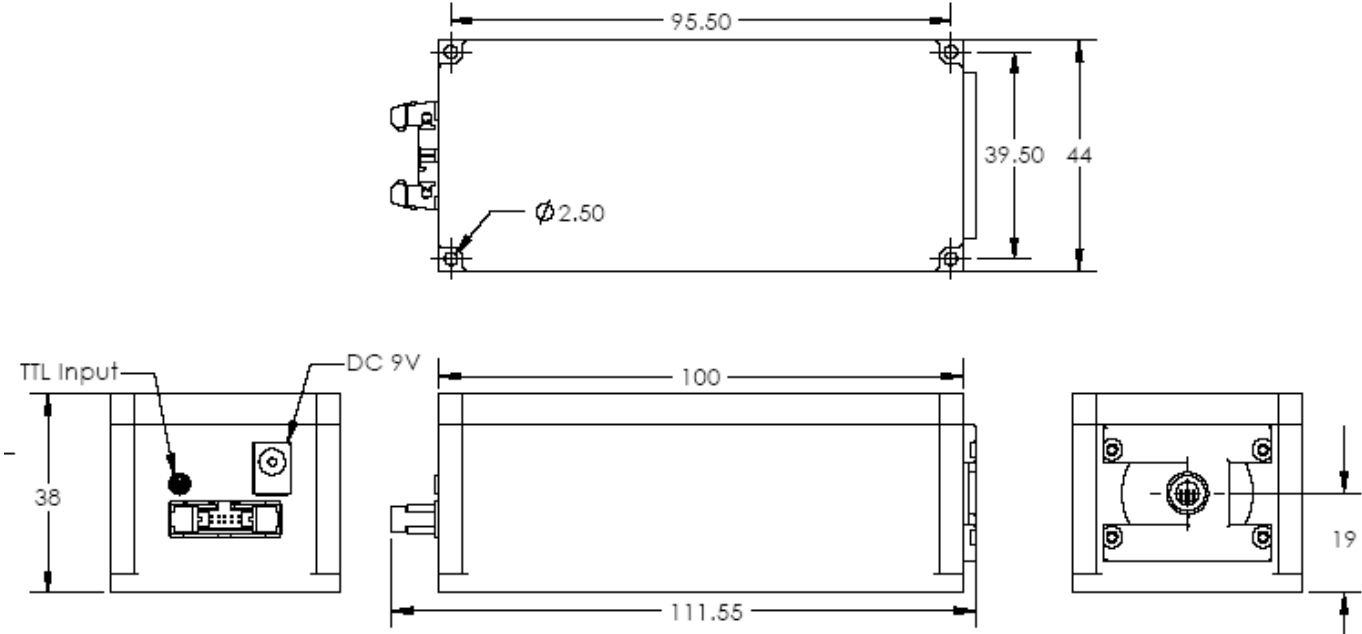

### Free Space Mechanical Dimension (Tube):

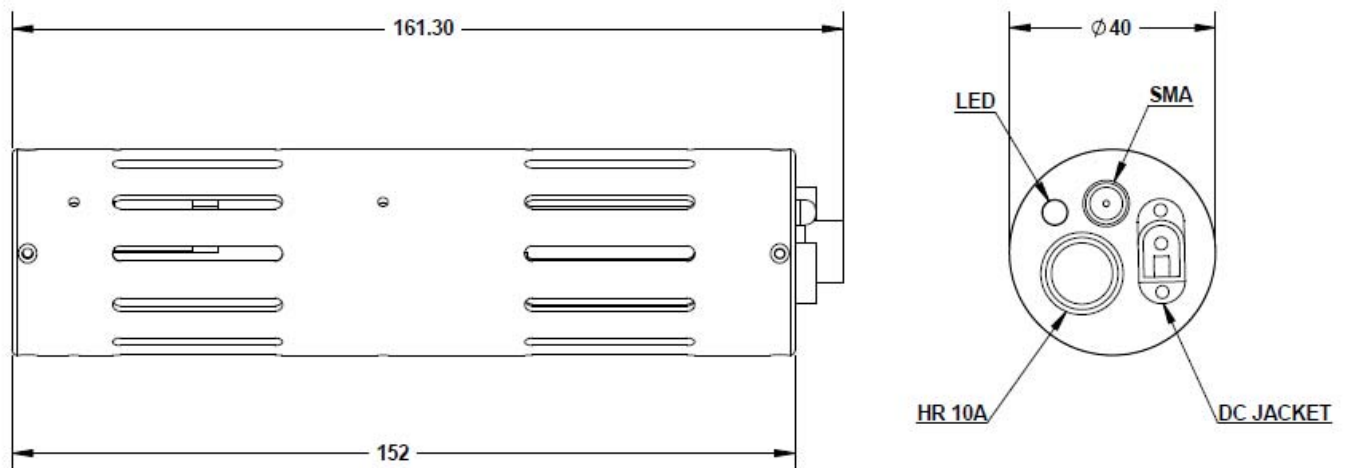

## Temperature Stabilized Semiconductor Laser Module

### Fiber Coupled Mechanical Dimension:

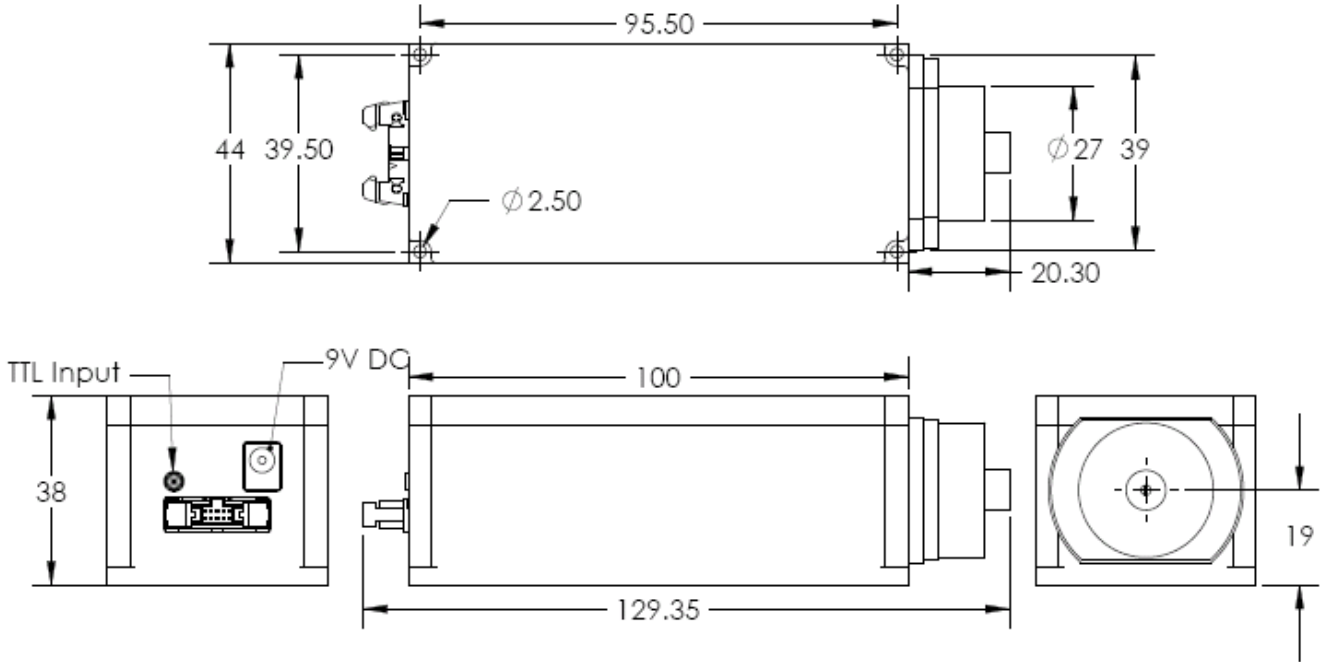

This component does not comply with the Federal Regulations (21 CFR Sub chapter 1) as administered by the Center for Devices and Radiological health. Purchaser acknowledges that his/her products must comply with these regulations before they can be sold to a customer. The output light from this product is

## Temperature Stabilized Semiconductor Laser Module

harmful to a human body even if it is invisible. Avoid looking at the output of this product directly, or through a lens during operation. Observance of operation should be through a TV camera or related equipment. Refer to IEC 825-1 and 21 CFR 1040.10-1040.11 as a radiation safety standard for laser products.

RgBLase LLC follows a policy of continuous product improvement. Specifications are subject to change without notice.